

VESA Compliant: Up to 450 wide x 300 tall  
Max Weight: 165 lbs

# Master<sup>TM</sup> Mounts

## Installation Instructions PLB-3



### UNPACKING INSTRUCTIONS

Carefully open the carton, remove the contents and lay them out on the cardboard or other protective flat surface to avoid damage.

Check the components against the supplied parts list on the next page to assure that all components were received and undamaged. Do not use damaged or defective parts.

### IMPORTANT SAFETY INFORMATION

Install and use this mount with care. Please read this entire manual before attempting installation and carefully follow all the instructions contained herein. Use Proper safety equipment during installation.

Please call a qualified installation contractor for help if you:

- Don't understand the instructions or have doubts about the safety of the installation
- You are uncertain about the structure and nature of your wall.

Do not use this product for any purpose or in any configuration not explicitly specified in these instructions. Master Mounts hereby disclaims any and all liability for injury or damage arising from incorrect assembly, mounting or any other incorrect use of this product.

**WARNING!**

**CAUTION!**

**WARNING!**



**This TV mount must be securely attached to the verticle wall. If the mount is not properly installed it may fall, resulting in possible injury and/or damage.**

#### TOOLS REQUIRED

- 3/16" Drill Bit
- Phillips Screwdriver

- 1/2" Masonary Bit
- Stud Finder

- Wrench or Socket Set
- Carpenter's Level

**Note:** The mounting components and hardware supplied in this package are not designed for installation to wall with steel studs. If the hardware you need for your installation is not included, please consult your local hardware store for proper mounting hardware for this application.

# Master<sup>TV</sup> Mounts

## Supplied Parts List



(1) Wall Plate - a



(1) Left TV Rail - b



(1) Right TV Rail - c



(10) Lag Bolt Washers - d



(6) 3/8" x 3.5" Lag Bolts - e



(6) Concrete Anchors - f

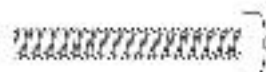

(4) M4 x 30 mm - i



(12) M4/M5 Washer - k



(4) 1/2" Plastic Spacers - l



(4) 3/4" Plastic Spacers - j



(4) M8 x 25 mm Screw - m



(4) M8 x 40 mm Screw - n

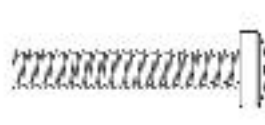

(4) M5 x 30 mm Screw - o



(4) M6 x 30 mm Screw - p

## STEP 1

### Connecting the Wall Plate (a) to the Wall

#### Wood Stud Mounting:

The Wall Plate (part a) **MUST** be mounted to two wood studs. Use a stud finder to locate two adjacent studs. It is a good idea to verify where the studs are located with an awl or thin nail as show in Diagram 1-A. Pre-drill an 50mm deep hole at the desired height in each stud using a 6mm drill bit. Make sure these holes are in the center of the studs and level with each other. Use the Wall Plate as a template to mark the location of the second hole in each stud. Drill pilot holes at each of the marked locations. Attach the Wall Plate to the wall using the 4 Lag Bolts (part e) and 4 Lag Bolt Washers (part d).

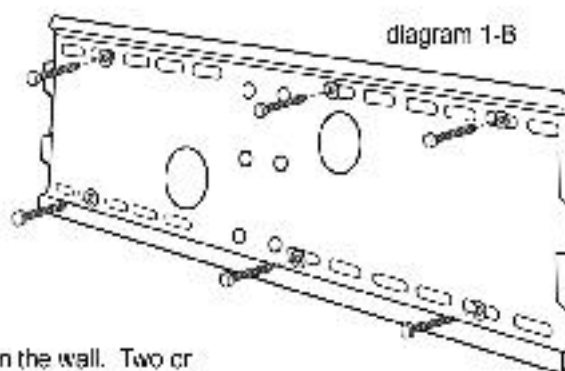
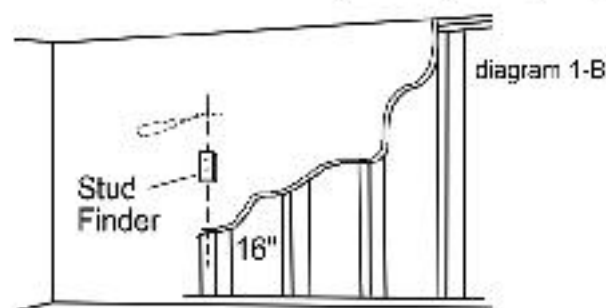

#### Brick, Solid & Block Concrete Mounting:

Use the Wall Plate (part a) as a template to mark 4 - 6 hole locations on the wall. Two or three in the top row of slots and three more in the bottom row. Make sure these holes are level and there is at least 8" distance between any two holes. Pre-drill these holes with a 10 mm masonry bit to at least 90mm in depth. Insert a Concrete Anchor (part f) into each of these holes. Make sure the anchor is seated completely flush with the concrete surface even if there is a layer of drywall or other material in front. Attach the Wall plate to the wall using 6 Lag Bolts (part e) and 6 Lag Bolt Washers (part d), as shown in Diagram 1-B.

# Master<sup>TV</sup> Mounts

## STEP 2

### Mounting the TV Rails to the back of your Panel TV

Make sure the TV Rails (part b & c) are mounted at an equal distance from the top of the TV and as close to the center as possible as shown in diagram 2-A. The safety latches on the bottom of the arms should face outward from the television. M4, M5, M6 & M8 bolts are included. If other sizes are required, they are available at your local hardware store. Plastic Spacers ( i & j ) are provided for use with M4 and M5 screws. Use these spacers for televisions with curved or recessed back panels as shown in diagram 2-B. For flat back panels, no spacers are necessary as shown in diagram 2-C. Make sure you are using the correct bolt size for your television. Some televisions have shallow threaded inserts. 4 extra spacers have been included to offset mounting holes if the bolts provided are too long. Never force a bolt in deeper than the mounting holes allow. Doing so may damage your television. Before hanging the television, tighten the screws on both TV rails so that the mechanism does not move during installation.

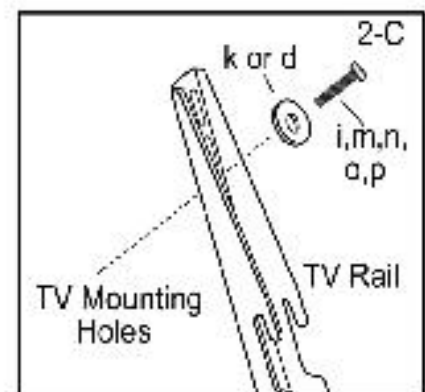
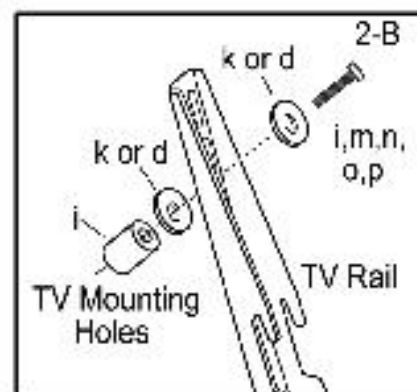
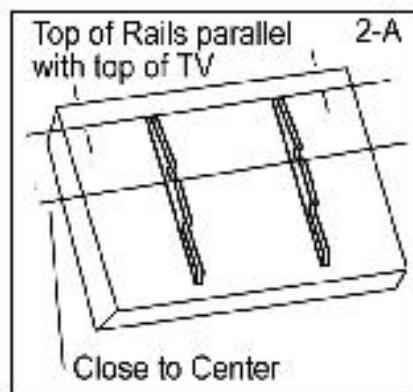

## STEP 3

### Hang the TV onto the Wall Plate

**Warning:** Some TVs may require two people to lift! Master Mounts is not responsible for personal injury or product damage.

First hook the Monitor Bracket (parts b & c) over the top of the wall plate (part a). Then, let the bottom of the monitor brackets rest on the bottom of the wall plate as shown in Diagram 3-A, 3-B. Slide up the safety latches on the bottom of each rail so that it engages the bottom tip of the wall plate and tighten the safety screws to lock the latch in place.

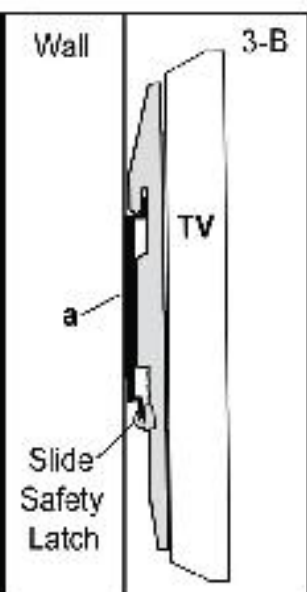
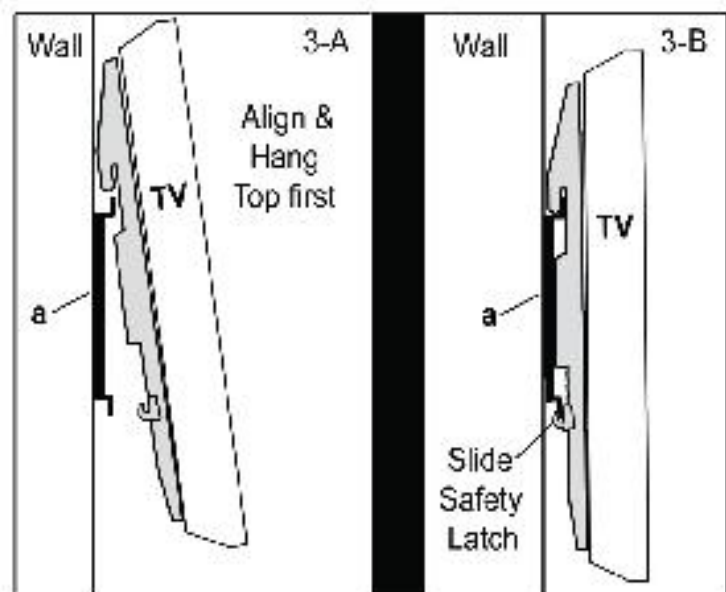

**Congratulations! You Are Finished**